

QUADRO ELETTRICO IN DOTAZIONE
ELECTRICAL PANEL

INGRESSO ACQUA 1" 1/4 GAS
WATER INLET 1" 1/4 GAS

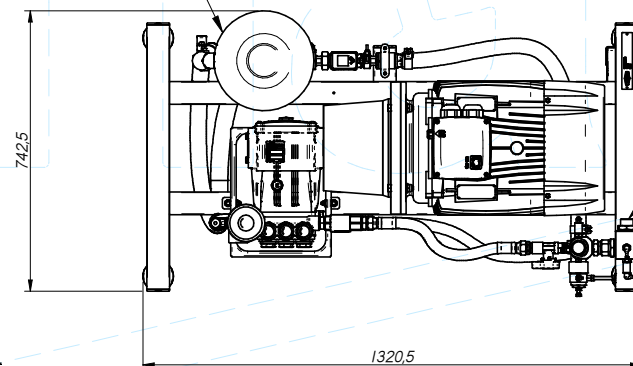

USCITA ACQUA 1" GAS
WATER OUTLET 1" GAS

NOTA: I DATI RIPORTATI SONO INDICATIVI - PRIMA DELL'INSTALLAZIONE FAR VERIFICARE DA UN TECNICO SPECIALIZZATO IL CORDINAMENTO DEGLI INTERRUTTORI CON L'IMPIANTO ESISTENTE.
NOTE: THE DATA PROVIDED ARE INDICATIVE - BEFORE INSTALLATION, CHECK OUT THE SWITCHING OF THE SWITCHES WITH THE EXISTING SYSTEM BY A SPECIALIST TECHNICIAN.

CARATTERISTICHE TECNICHE - TECHNICAL DETAILS		CARATTERISTICHE TECNICHE - TECHNICAL DETAILS	
DIMENSIONI DIMENSIONS LxHxP	1320 X 1240 X 742,5	POTENZA POWER	30 KW
PESO WEIGHT	575 KG	PRESSIONE REGOLABILE ADJUSTABLE PRESSURE	20 - 150 Bar
TEMPERATURA MAX ALIMENTAZIONE INPUT MAX TEMPERATURE	75°C - 167 °F	PORTATA FLOW	90 L/min
GIRI MOTORE ENGINE RPM	1000 RPM	RACCORDO INGRESSO INLET FITTING	1" 1/4 GAS
TENSIONE VOLTAGE	400 V 3P+N+PE	RACCORDO USCITA OUTLET FITTING	1" GAS
QUADRO ELETTRICO ELECTRIC PANEL	806 X 648,5 X 319 IP65	PESO QUADRO ELETTRICO WEIGHT ELECTRICAL PANEL	225 KG

TUBI IN DOTAZIONE :

1 PZ. COD. 10.4492.00 TUBO INGRESSO R1 1" RACCORDATO DR+DR L=1500
1 PZ. COD. 10.4493.00 TUBO USCITA R2 1" RACCORDATO DR+DR L=1500

TUBES IN EQUIPMENT:

1 PCS COD. 10.4492.00 R1 1" INLET TUBE ST + ST FITTED L=1500
1 PCS COD. 10.4493.00 R2 1" OUTPUT TUBE ST + ST FITTED L = 1500

 Tecnologie di lavaggio <small>LA DITTA VEMA S.R.L. SI RISERVA TUTTI I DIRITTI A TERMINI DI LEGGE.</small>		Via Messina 18 20831 Seregno (MB) Tel. 0362-223464 Mail: info@vemaimpianti.it Site: www.vemaimpianti.it	
		REV: 03 del 31/07/2023 UFFICIO TECNICO	MODULA PLUS 2 POMPE 45LT-150BAR 15KW MODULA PLUS 2 PUMPS 45LT-150BAR 15 KW
Data (Date) 02/11/2022	Foglio (Sheet) 1 di 1	N° Articolo (Art. Item) 10.3715.00	EX. Cod. VEMA: 429015